



**Sunshade  
Experts**

en 27-03-2019

Installation manual

# FORMOSA







FORMOSA cassette awning with adjustment of slope using an independent rack system.

- Alignment of the arms: from the external threaded stud of the support.

- Slope: 6 - 60° (wall mounting) and 18° - 60° (ceiling mounting).

This model allows a width of 5.00 m. with no need of intermediate supports.

### Icon legend



Use with sun



Don't use with snow



Don't use with rain



Don't use with hail



Use with sun and rain



Class by N. of cycles



Crank



Motorized



Danger! Strong arm tension



Splendor 300



Splendor 400 Onyx



WIN



ART-500



EVO front profile



Univers front profile



28 Km/h



38 Km/h



Information



Made in Europe



CE standards



Inox



Width



Projection



2 years of warranty



3 years of warranty



Eco-friendly

## Product parts

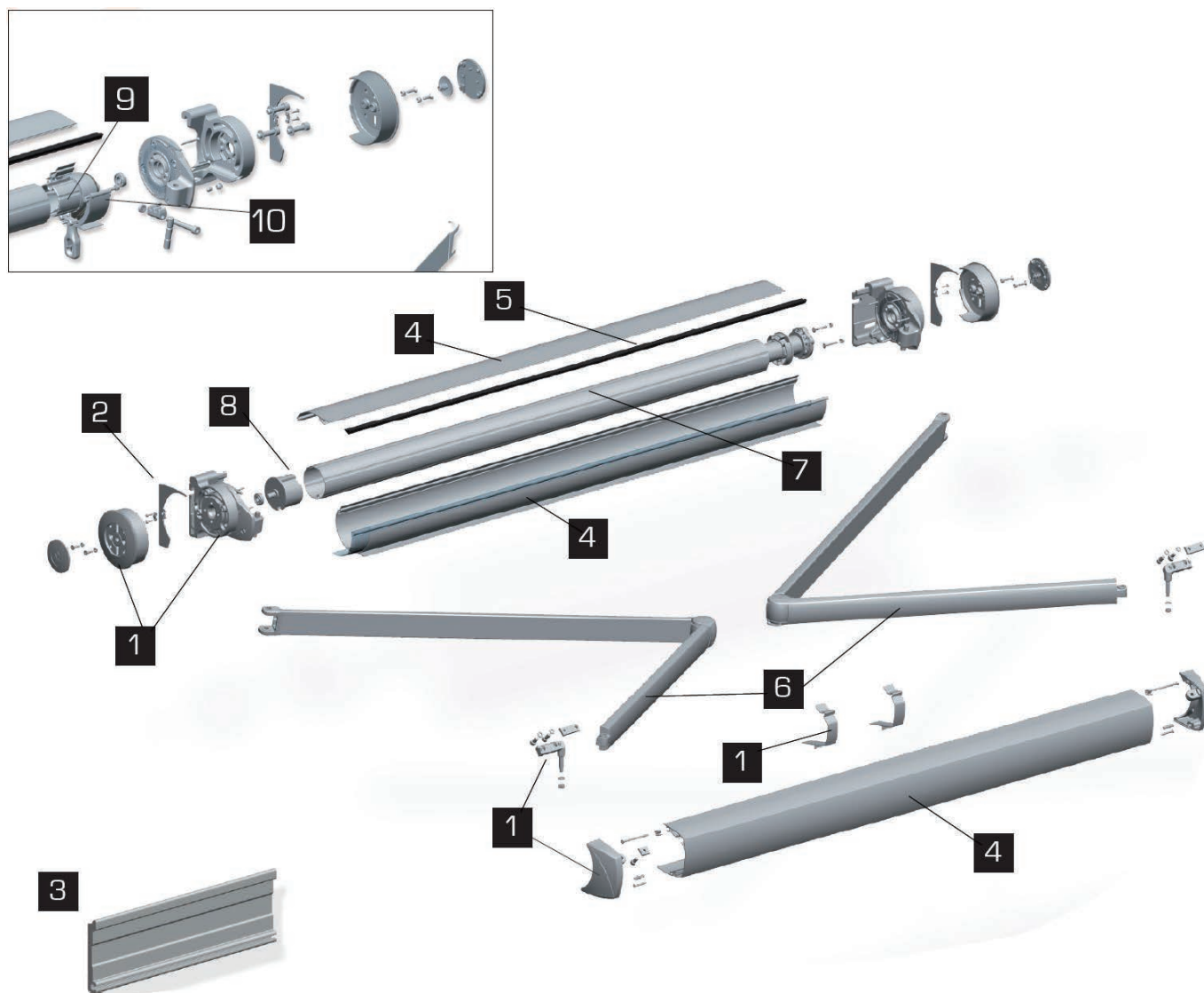

## Nomenclature

- 1** Support set and caps Formosa
- 2** Concealment caps
- 3** Long fixing plate for cassette
- 4** Cassette profiles kit
- 5** Rubber sealant profile
- 6** Formosa arms set
- 7** Rolling tube
- 8** Roller end bearing
- 9** ZNP Gearbox
- 10** Kit for gearbox drive

THIS MODEL CAN ALSO BE ASSEMBLED WITH VRCTOR ARMS





WALL MOUNTING (mm)

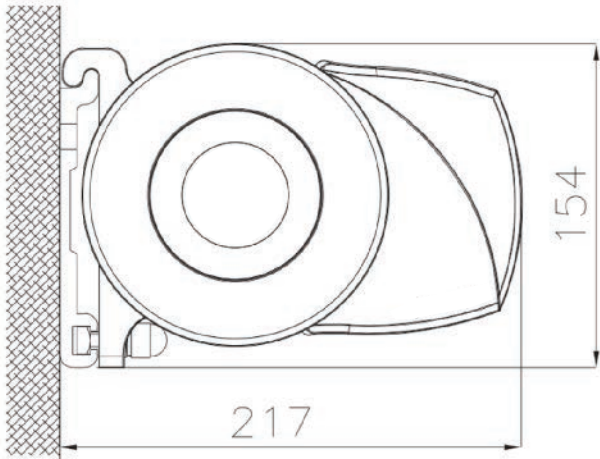

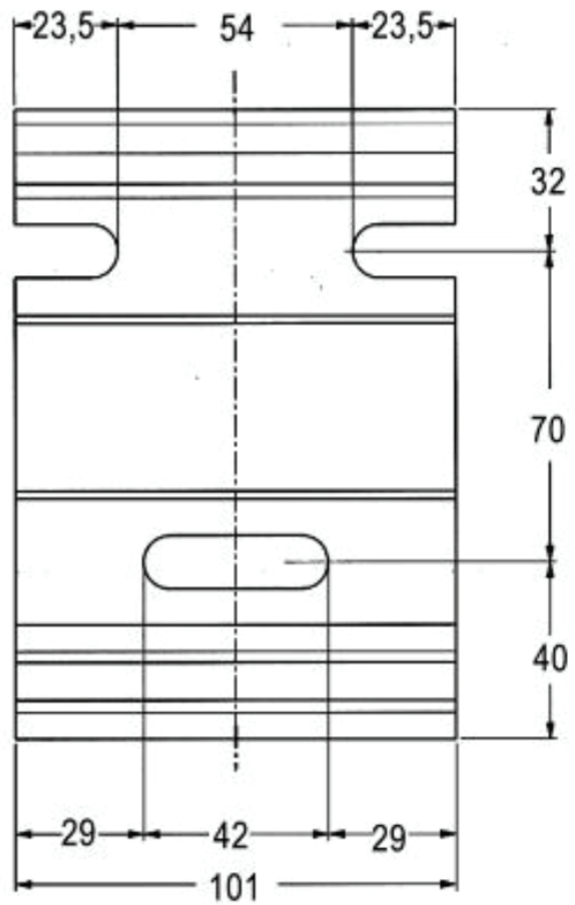
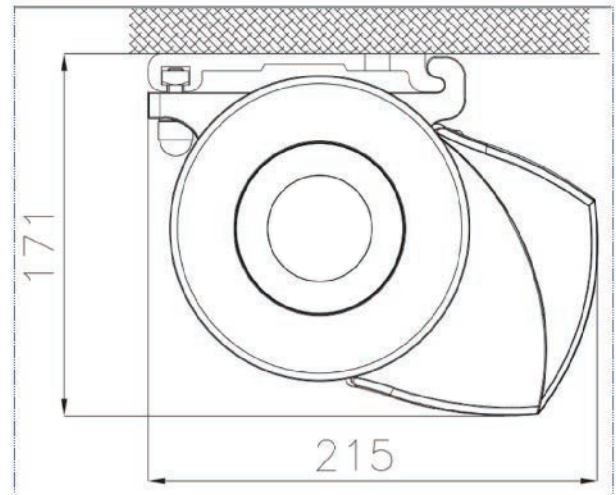

CEILING MOUNTING (mm)



WALL- CEILING FIXING PLATE

## Selection motor table



		Projection (m)						
		1,50	1,75	2,00	2,25	2,50	2,75	3,00
	Rolling tube Ø 70mm	25 Nm		30 Nm		40 Nm		
	Rolling tube Ø 80mm	30 Nm		40 Nm		55 Nm		

Classification according to European standards: EN 13.561:215



 c.2 +38Km/h	Arm projection (m)		Width		Class	
		3,00		5,00		C.2

## Information about cycles and class



The arms have a protective band for correct identification:

**GREEN:** Right hand side viewed from outside

**RED:** Left hand side viewed from outside



NEVER EXTRACT THE SAFETY TENSION BANDS UNTIL THE ARM HAS BEEN FIXED TO THE FRONT PROFILE.

## Recommended tools and accessories for installation procedure

i



### Width

Total width for interior gearbox or motor (L)

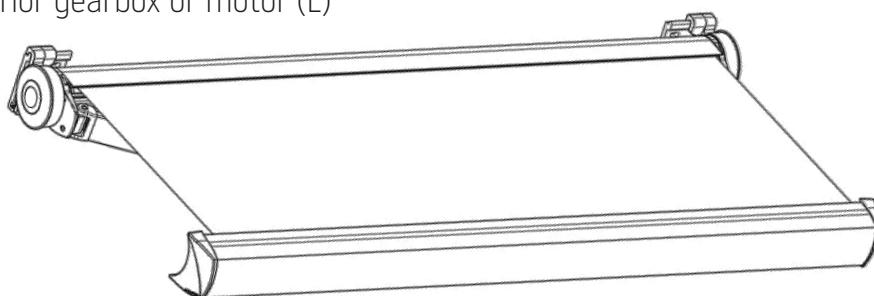

### Installation instructions

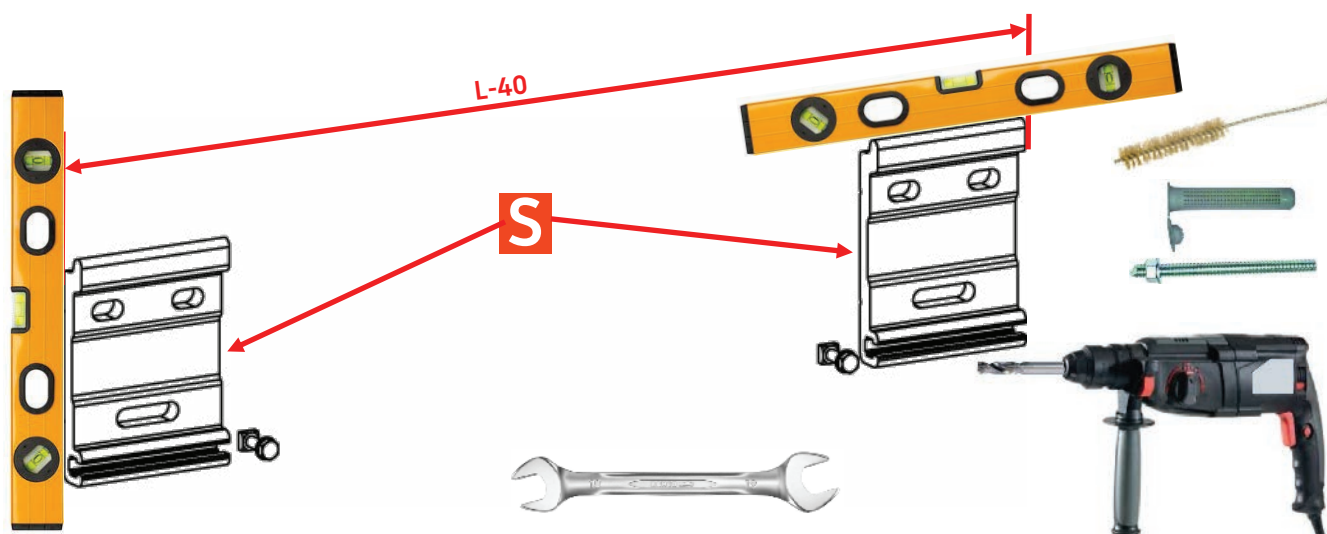

The distance between the exterior part of the wall plates, when using the side cover kit, should be: L-40 mm, when L=total width



## Installation instructions

Fixing the cassette support to the wall bracket

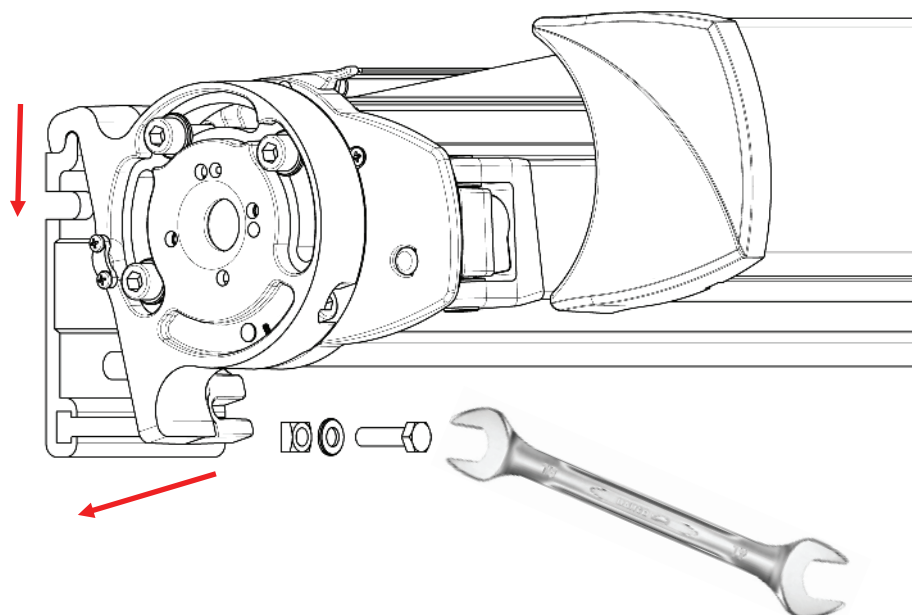

## Installation instructions

To change the cassette slope proceed as indicated in the drawing

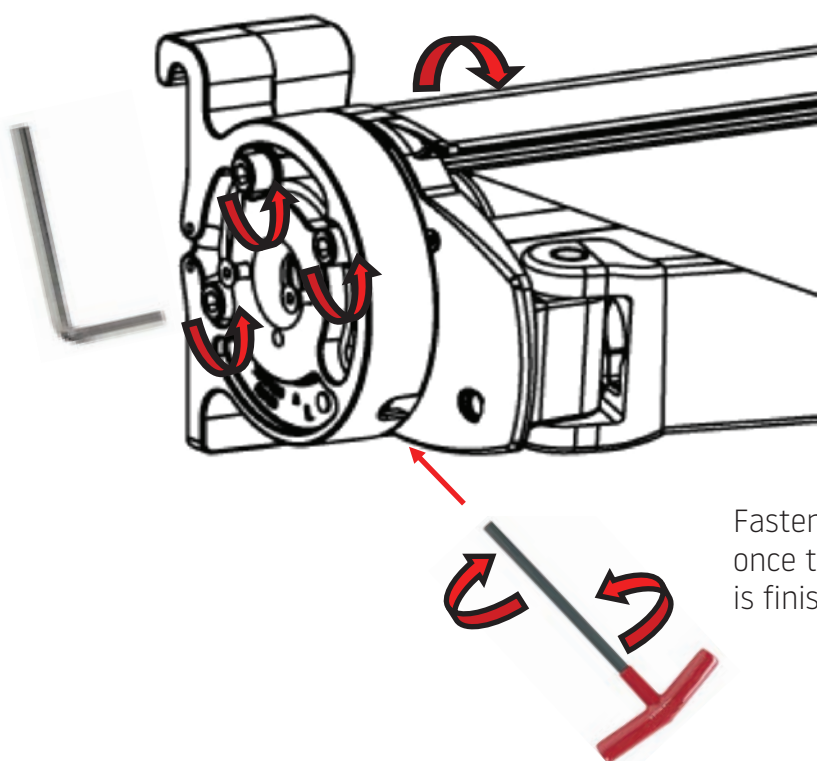

Fasten the three screws once the adjustment is finished



To modify the alignment of the arms, proceed as follows.

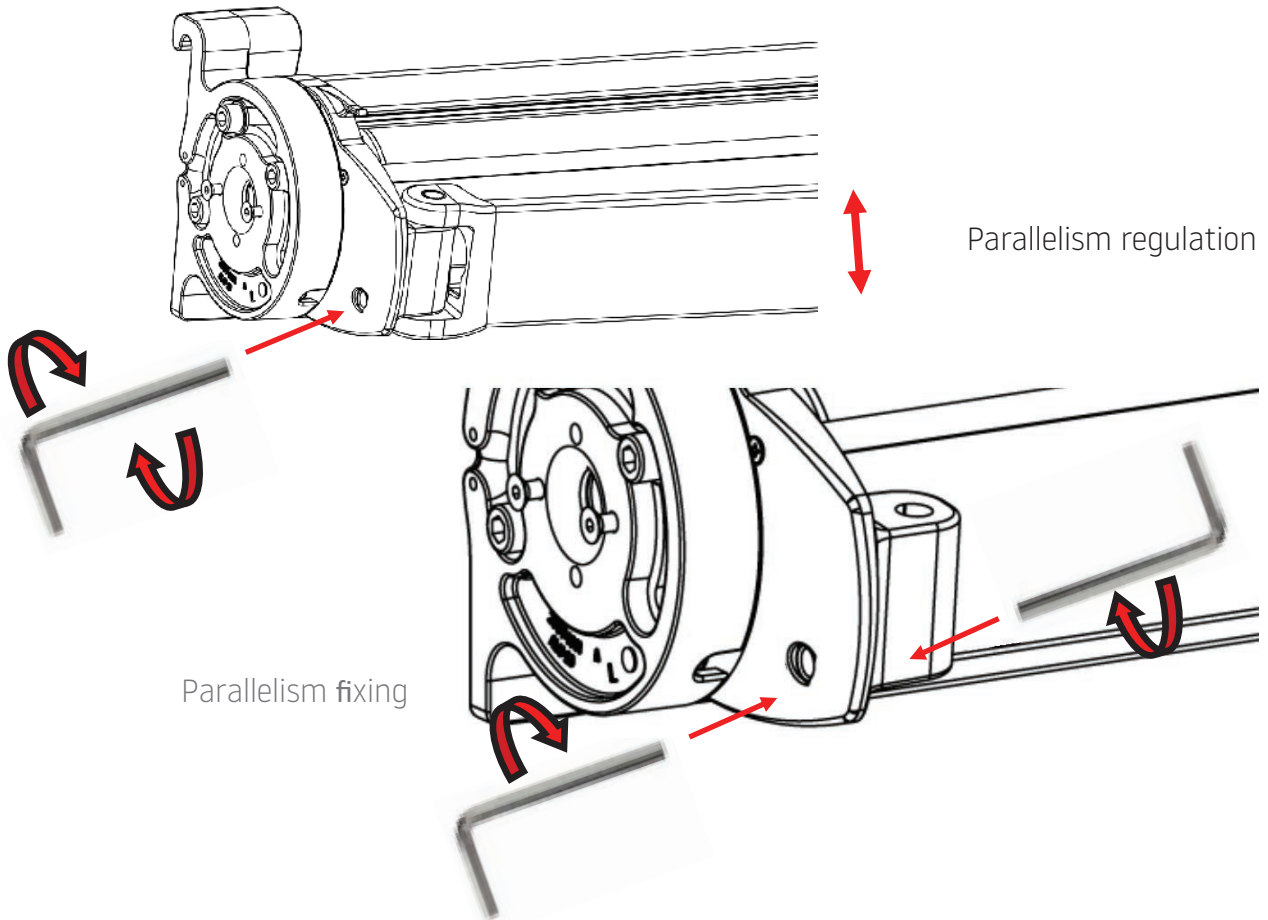

Positioning distance for the front rail connectors measured from the end of the front profile to the outer end of the front rail connector.

i

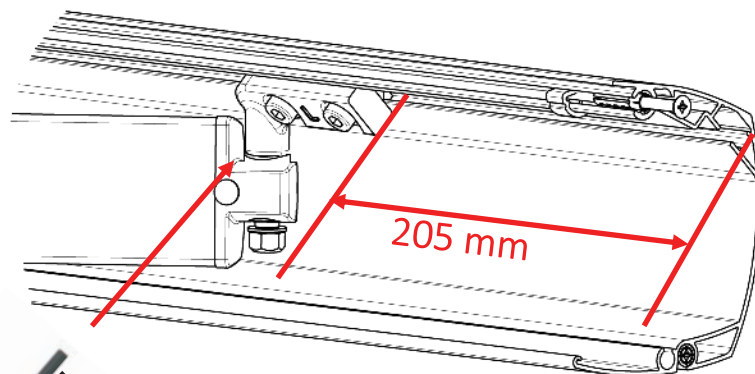

**VERY IMPORTANT:** The screws for the front rail connectors must be oriented towards the outside (as shown in the drawing).

## BASIC NOTES ON ASSEMBLY AND INSTALLATION:

- Assembly and installation should be done by trained personnel.
- **IMPORTANT SAFETY CONSIDERATIONS:** For proper installation of the awning, the instructions for assembly and installation must be carefully followed step by step. Keep plastic bags or any other mounting pieces out of children's reach.
- Do not alter the design or the configuration of the system, nor modify the installation method without consulting the manufacturer or an authorised representative.
- If the awning is motorised and there is a switch, this should be placed so that the user does not interfere with the movement of the awning, and at a height of less than 1.3 metres when possible.
- If the awning is manually operated, it should be accessible at a height of 1.8 metres.
- If the awning is to be installed in windy areas where there are frequent blackouts, manual operation or the use of a back-up generator is recommended.
- When motorised units are inspected or repaired, always disconnect them from the power supply.

## BASIC NOTES ON ASSEMBLY AND INSTALLATION:

The awning must be rolled away:



- In the event of ice, if operation is particularly difficult and in the absence of safety measures, stop the operation until more favorable conditions prevail
- During opening and closing, make sure there is no obstacle which could get in the way. **NEVER FORCE THE AWNING!** If the awning does not move at all when you try to operate it, call a professional installer.
- In the case of motorized awnings, it should be borne in mind that the motor features a thermal safety device to avoid overheating and breakdowns. This device is activated when the operating switches are pressed insistently.
- Do not submit the installation to additional loads or stresses not covered by the manufacturer's
- Configuration. Do not interfere with the system's fixing components.
- Examine the installation if it has been subjected to adverse weather conditions, and if any repairs are needed do not use it. In such cases, a professional installer should be called.
- Keep the installation clean and in good condition. A yearly maintenance check by an authorized professional installer is recommended.



**IMPORTANT SAFETY INSTRUCTIONS.** The system has powerful springs inside it. In the event of poor installation, these may cause the awning to open sharply. If any irregularities are observed during opening and/or closing, call a professional installer. To avoid possible damage, do not allow children to play with the awning.



